

# ECOKRAFT MATERIAL BUNKER MB-LX

## COLLECT, STORE & CONVEY

### AREAS OF APPLICATION

The ECOKRAFT MB-LX material bunker is a perfect solution for filling the pellet mill. Thanks to its high-quality workmanship and the use of food-safe paints in the interior, the material bunker is suitable for a wide variety of fine bulk materials, whether for energy, fertilizer, bedding or feed.

All components are manufactured disproportionately and ensure long usability. Thanks to the use of level sensors, the material bunker can be operated fully automatically with the start/stop function. Integrated frequency converters also ensure a perfectly adjustable conveying speed.

### ADVANTAGES

- ✓ High quality and solid construction
- ✓ Extra mixer to avoid bridging
- ✓ Automated filling of the pelleting press possible
- ✓ Easy operation

### ECOKRAFT MATERIAL BUNKER MB-LX

The steel material hopper with screw discharge and closed material conveying system is extremely variable. Variants offered are the material hopper with capacities of 3, 4, 6 or 10 cubic meters. Special agitators are used to prevent bridging. Optional: filling level sensor and extra reinforced frame for the installation of a clean air extraction system.



Simple unfolding mechanism

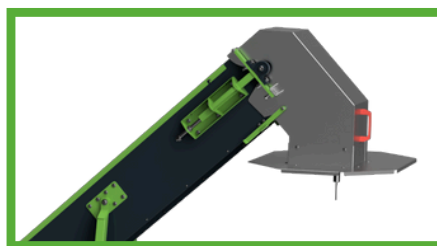

Integrated dust seal as a transition to the pellet mill

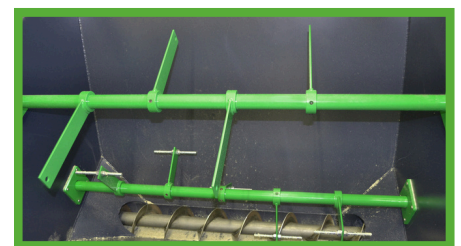

Integrated agitator to prevent bridging with very light material



## SPECIFICATIONS

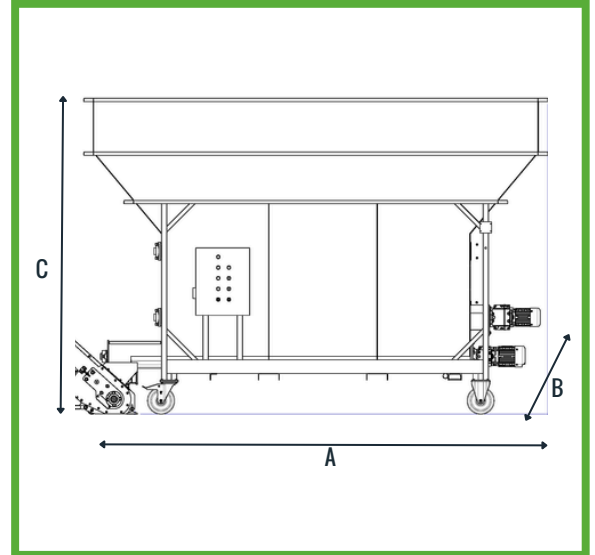
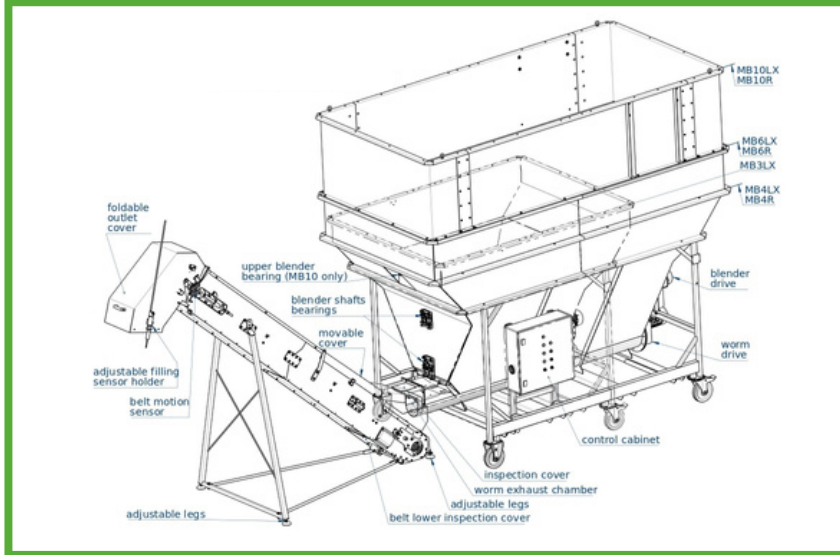

TYPE	MB3-LX/duo	MB4-LX/duo	MB6-LX/duo	MB10-LX/duo
<b>Supply voltage</b>	3 x 230 / 400V	3 x 230 / 400V	3 x 230 / 400V	3 x 230 / 400V
<b>Mains frequency</b>	50 Hz	50 Hz	50 Hz	50 Hz
<b>Connected current</b>	16 A	16 A	16 A	16 A
<b>Control voltage</b>	24 V DC	24 V DC	24 V DC	24 V DC
<b>IP degree of protection</b>	IP55 / 20	IP55 / 20	IP55 / 20	IP55 / 20
<b>Weight</b>	530 kg / 665 kg	715 kg / 890 kg	875 kg / 1,050 kg	1,170 kg / 1,350 kg
<b>Length A*</b>	2,250 mm	3,400 mm	3,400 mm	3,400 mm
<b>Width B*</b>	1,750 mm	1,750 mm	1,750 mm	1,750 mm
<b>Height C*</b>	2,950 mm	1,945 mm	2,344 mm	3,104 mm

\*material bunker only, without conveyor belt

Variants: Discharge with conveyor belt or screw conveyor (depending on material)

**Note: Control of material bunker via pellet mill; technical specifications from pellet mill.**

